

# Tomahawk C12

Bale Processor

**Teagle**



**CALBRATOR**

# Calibrator

A High Capacity Mill for processing dry materials such as straw and miscanthus to a consistently short length for Bedding, Feeding and Biofuel Applications. Calibrate material length from 20mm - 100mm.



**POULTRY  
BEDDING**



**DAIRY RATIONS &  
CUBICLE BEDDING**



**BEEF  
RATIONS**



**ENERGY  
CROPS**



## 3 easy steps, just 1 operator

Straightforward setting of material calibration ensures you get up and running in minutes. Manage bale processing remotely from the loader vehicle via wireless Bluetooth® control, with no tractor operator required.

### SET



- Select suitable screens for your application and unfold conveyor to the desired discharge height.
- Remove bale strings, run the C12 up to operating speed (1000rpm PTO), and load the bale chamber.

### PROCESS



- Material is processed against a pair of interchangeable and reversible quarter circle screens below the rotor.
- When material has been processed to the desired length it falls onto the discharge conveyor.

### OPTIMISE



- Tractor power loading is controlled remotely from the loader vehicle via Bluetooth®.
- To maximise throughput and prevent overloading, the C12 governs bale chamber rotation automatically.



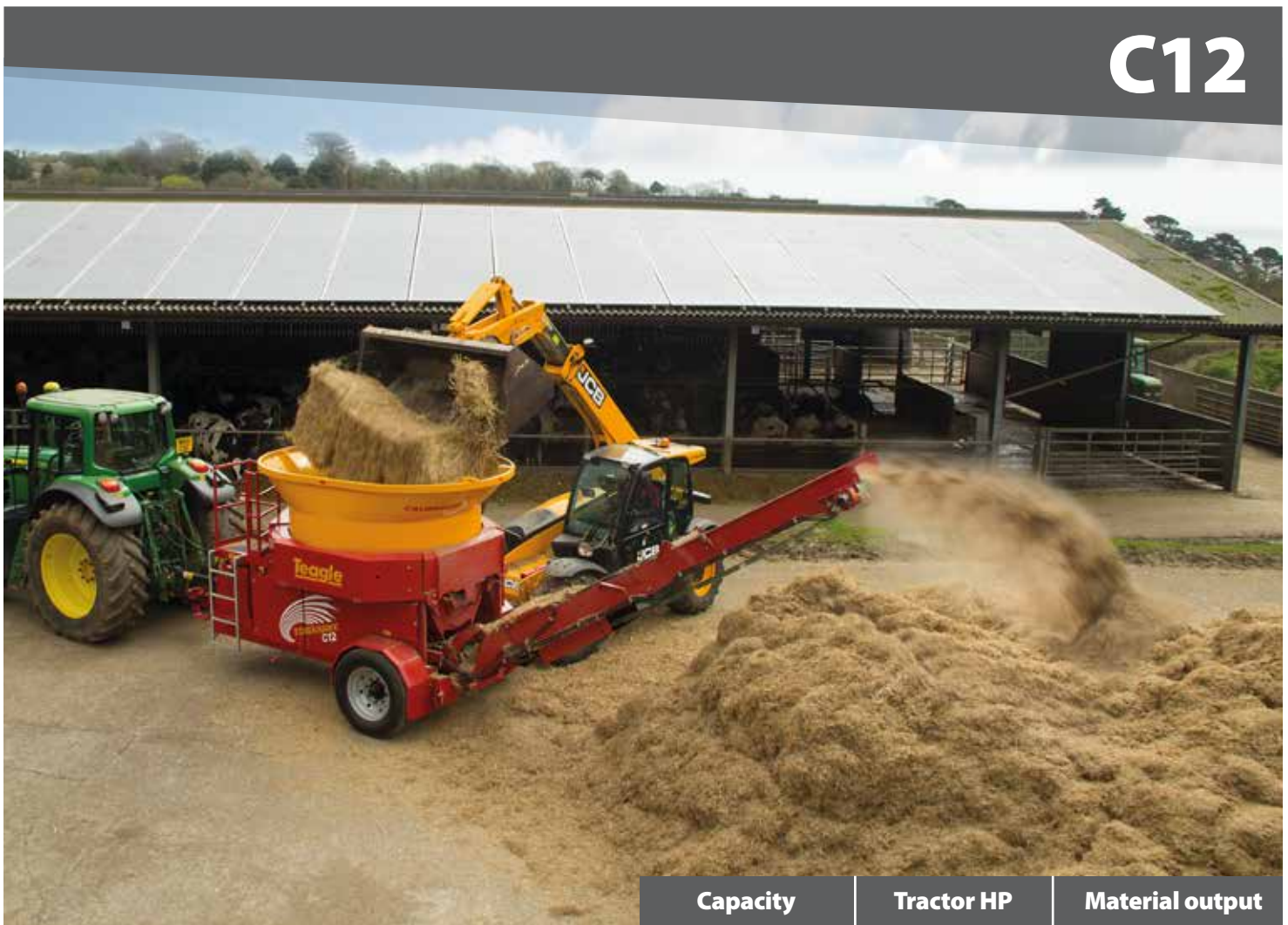

**SUITABLE FOR:** Materials up to 20% moisture content including forage, bedding and energy crops.

Capacity	Tractor HP	Material output
Up to 11t/hr	120 - 200	20 -100mm

## The Consistent Performer

Designed for Contractors and Large Scale Operators. Process up to 25 quadrant bales per hour (subject to straw quality) to a consistently short length.



“Straw is a very useful feed if prepared in the right way.”

- In dry cow rations it can be used to control energy intake and reduce the risk of milk fever.
- In milking cow rations it can be very useful as physically effective fibre when required.

“With improved and more consistent straw intakes we are better equipped to control metabolic stress in fresh cows, which can cause issues such as retained placenta and metritis. Getting off to a better start these cows have less negative energy balance and sub-clinical ketosis. Straw rations can also help prevent milk fever.”

Andy Hawken AMTRA, DipRN Three Counties Feeds



# Take a closer look ...

## 1 Automatic Power Loading

Rotor speed is monitored and bale chamber rotation automatically governed to optimise output for available tractor power. Operator can override bale chamber rotation from the loader vehicle.

## 2 Operator Information

A beacon on the viewing platform indicates low rotor speed, warning against either entering or loading more material into the bale chamber. A ground level stop button is fitted to instantly stop the conveyor and bale chamber rotation.

## 3 Safe Road Transport

The C12 is homologated to 40km/hr, incorporating Air/Hydraulic braking combinations, approved 285/55 R22 wheels, 300mm x 90mm Brake Drums and various hitch options. Road lighting includes LED lamps and strobe, as well as statutory side markers.

## 4 Independent Hydraulics

Protect the tractor hydraulic oil from overheating and contamination with the independent 150 litre oil system, fitted with auto-reverse cooling fan.

## 5 High Capacity Driveline

The driveline has shearbolt protection, overrun protection, and finally a massive 8 belt drive system with 200HP capacity.

## 6 Spare Screen Storage

Up to four optional spare screens, as illustrated, can be stored in a rack positioned within the C12 body for safe transport and instant access on farm.

## 7 Ease of Maintenance for Reliability

A ladder and platform to provide a safe viewing position into the bale chamber. Hinged maintenance covers and a centralised greasing banks for the driveline ensure straightforward routine maintenance.

## 8 Folding Conveyor

The hydraulic drive conveyor minimises dust and can deliver milled material up to 4.2m high into a trailer or onto a bunker pile. Conveyor can be folded from the comfort of the tractor seat. Optional deflector for loading trailers illustrated.

## 9 Lozenge Bale Chamber

Is designed to fall within the legal road transport width. It can easily be loaded with a tractor fore-end loader or telehandler. A heavy duty double pitch chain drives the Bale Chamber, which sits on and is guided by large diameter rollers and axles.

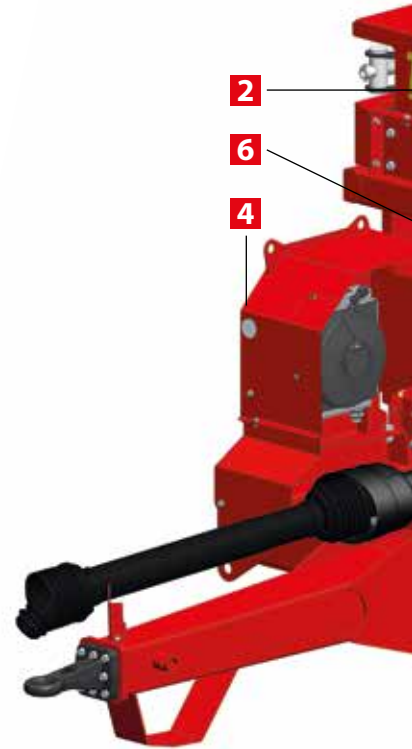

## Operator benefits



### Calibrate Output

Quick change screens can be switched at ground level in minutes. The two-part screens are reversible and can be fitted in various combinations to control output of finished product.



### Stay in Control

A robust Bluetooth® control desk provides remote control of power loading and bale chamber rotation from up to 50m away in the cab of the loading vehicle.



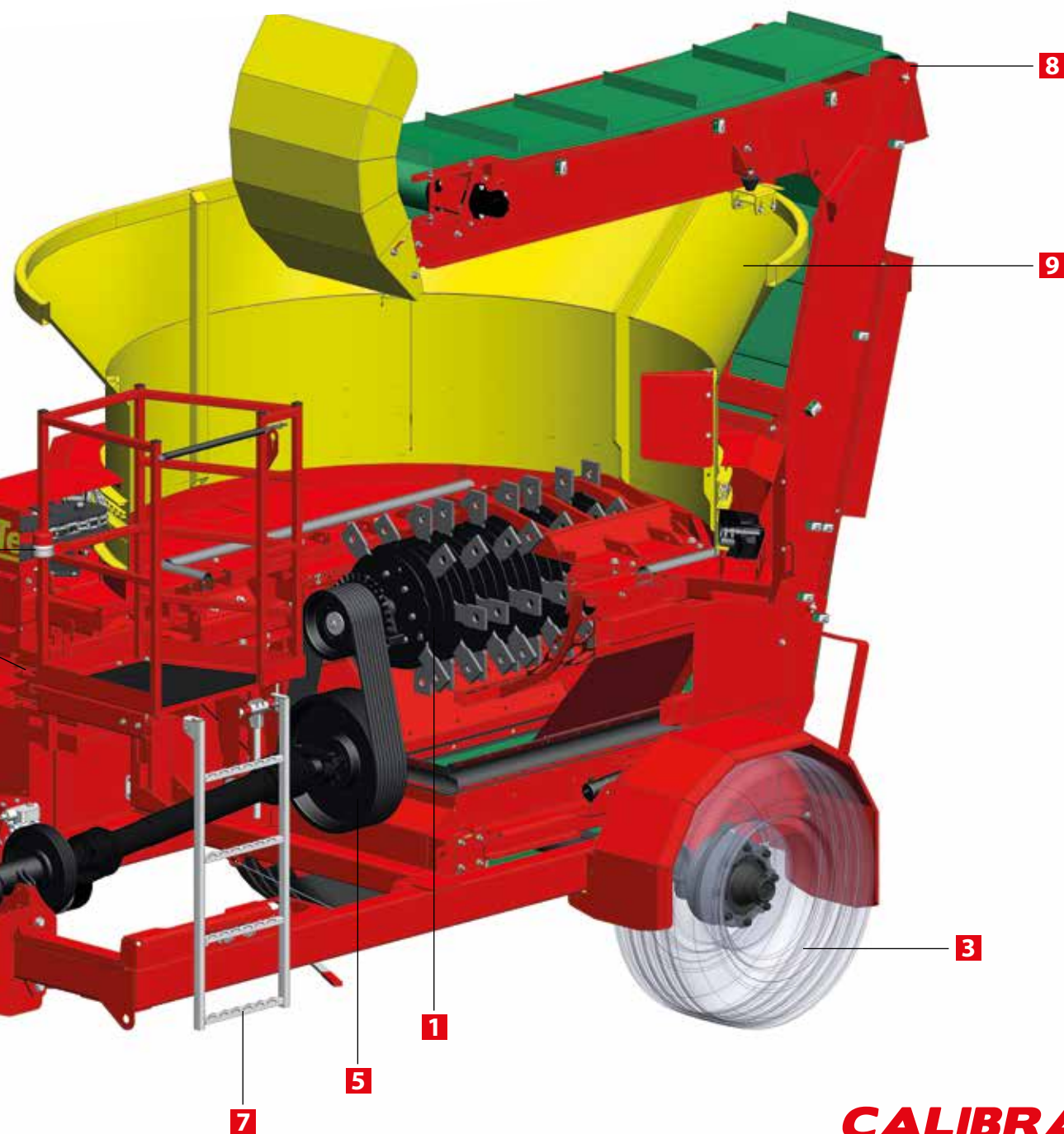

### Long Service Intervals

Hammers are through-hardened boron steel with ARMATECH PLUS® edge facing. Each hammer has 4 wearing edges and runs on a hardened bush.



### Safety on the Move

High specification running gear and chassis ensures compliance to European Homologation Standards up to 40km/hr.

# The cutting edge

## High Capacity Rotor

- ✓ Rotor speed is 2000rpm, generating a tip speed of 73m/s.
- ✓ Rotor is fitted with 56 through-hardened boron steel hammers with ARMATECH PLUS® edge facing.
- ✓ Heavy duty 15mm hammers rotate on hardened bushes to ensure durability of the removable retaining rods.
- ✓ Anti-vibration mounts minimise wear and tear, and operating noise.

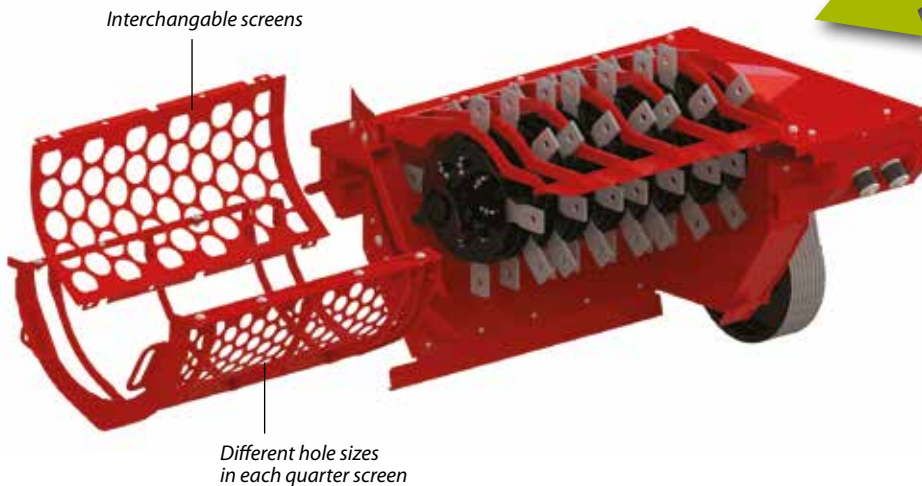
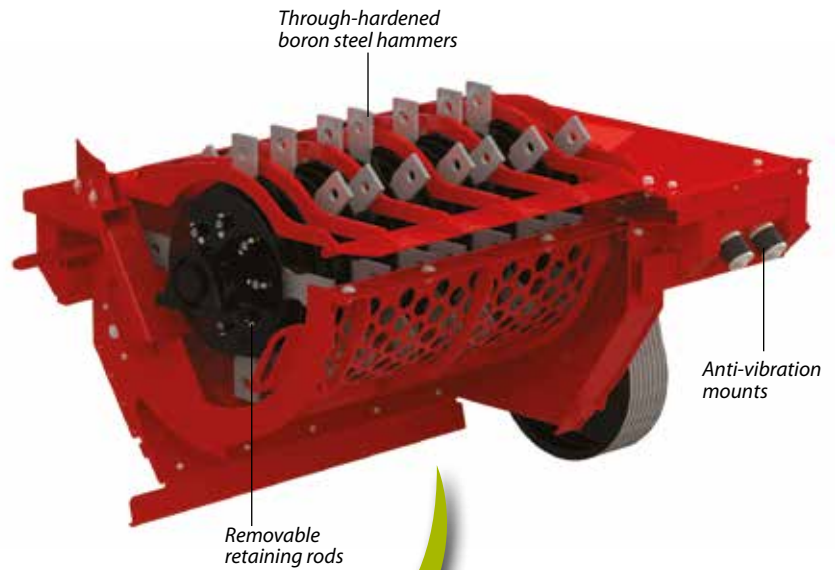

## Quick change screens

- ✓ Screen switch is achieved at ground level from the rear of the C12, with no need to climb into the bale chamber.
- ✓ Interchangeable screens comprise two quarter circle sections that are reversible when worn to maintain milling performance.
- ✓ For additional cut control, hole sizes in each quarter screen can be different.

## Screen options

- The C12 is supplied with a set of two quarter circle screens as standard.
- Screens are available with 100mm, 75mm, 60mm, 40mm, 30mm and 20mm hole sizes.
- Up to 4 additional spare screens can be stowed in a rack located inside the C12.

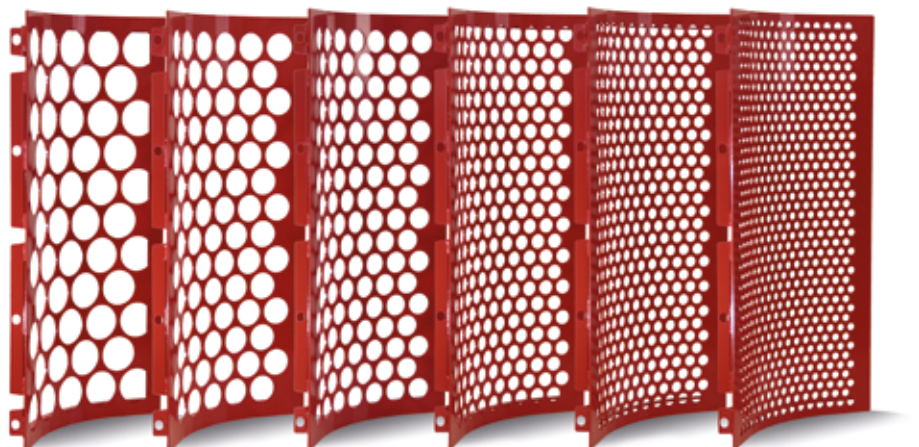

# Specifications

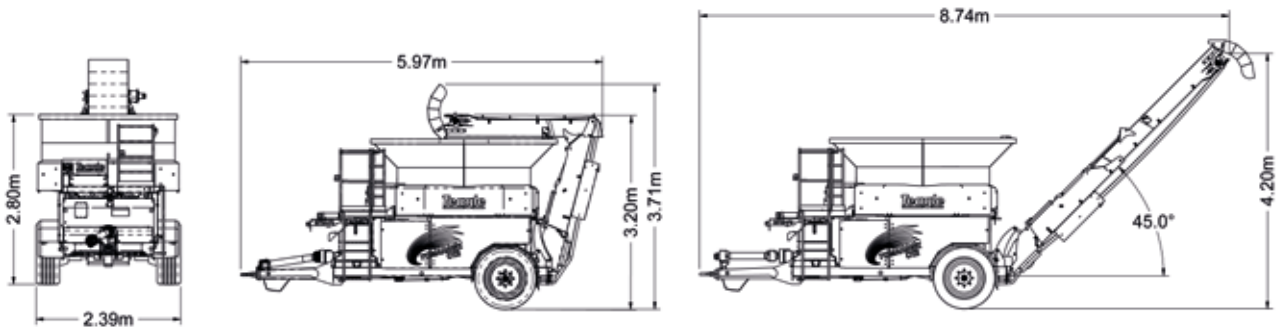

## General

Bale chamber diameter at base	2.20m
Bale chamber loading diameter	2.20m/3.00m

Weight	4200kg
PTO speed	1000rpm

## Transport

Transport width	2.39m
Transport length	5.97m
Transport height	3.20m

## Working

Working length	8.74m
Conveyor discharge height (variable)	4.20m
Loading height	2.73m



## Options

### Additional Screens

Quick Change Screens available with 100mm, 75mm, 60mm, 40mm, 30mm and 20mm sizes. (2 screens as standard with machine)

### Drawbar Hitch and Jack

An optional 80mm ball hitch can be specified in lieu of the standard bolt-on ring hitch. A manual jack is available for either hitch type.

### Conveyor Deflector

Control straw discharge when filling a trailer.



# Teagle

With over 30 years experience designing, manufacturing and supporting The Tomahawk range of Bale Processors, Teagle has established a reputation for performance and reliability, offering feeding and bedding solutions for all applications.

**Call our Sales Desk:  
01872 560592**

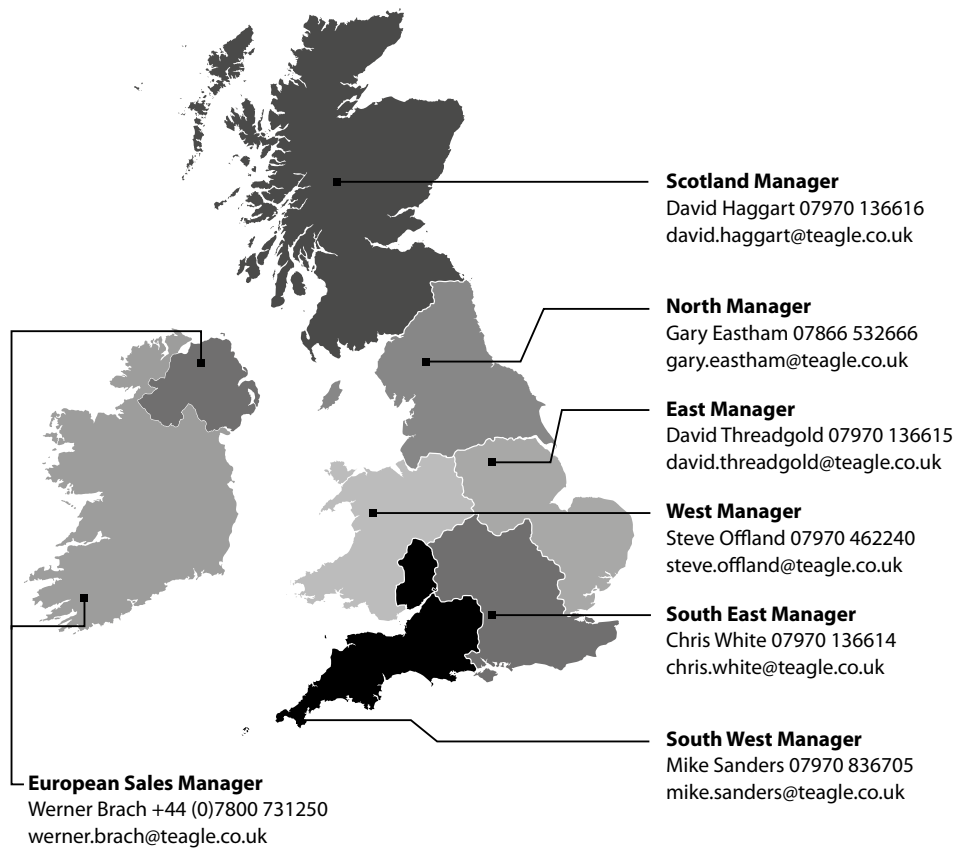

**T400/T500**



**T7100**



**T8100/T8500**



**T9500/T1010**



**TELEHAWK**



# Teagle

**Teagle Machinery Ltd**

Blackwater, Truro, Cornwall TR4 8HQ  
sales@teagle.co.uk www.teagle.co.uk

Tel: 01872 560592